

# How Inverters Work

By James Worden and Michael Zuercher-Martinson

## What Goes on Inside the Magic Box

One of the most incredible things about photovoltaic power is its simplicity. It is almost completely solid state, from the photovoltaic cell to the electricity delivered to the consumer. Whether the application is a solar calculator with a PV array of less than 1 W or a 100 MW grid-connected PV power generation plant, all that is required between the solar array and the load are electronic and electrical components. Compared to other sources of energy humankind has harnessed to make electricity, PV is the most scalable and modular. Larger PV systems require more electrical bussing, fusing and wiring, but the most complex component between the solar array and the load is the electronic component that converts and processes the electricity: the inverter.

In the case of grid-tied PV, the inverter is the only piece of electronics needed between the array and the grid. Off-grid PV applications use an additional dc to dc converter between the array and batteries and an inverter with a built-in charger. In this article we discuss how inverters work, including string, or single-phase, and central, 3-phase inverters; explore major inverter functions, key components, designs, controls, protections and communication; and theorize about future inverter technology.



## KEY INVERTER FUNCTIONS

Four major functions or features are common to all transformer-based, grid-tied inverters:

- Inversion
- Maximum power point tracking
- Grid disconnection
- Integration and packaging

**Inversion.** The method by which dc power from the PV array is converted to ac power is known as *inversion*. Other than for use in small off-grid systems and small solar gadgets, using straight dc power from a PV array, module or cell is not very practical. Although many things in our homes and businesses use dc power, large loads and our electrical power infrastructure are based on ac power. This dates back to the early days of Edison versus Tesla when ac won out over dc as a means of electrical power distribution.

An important reason that ac won out is because it can be stepped up and travel long distances with low losses and with minimal material. This could change in

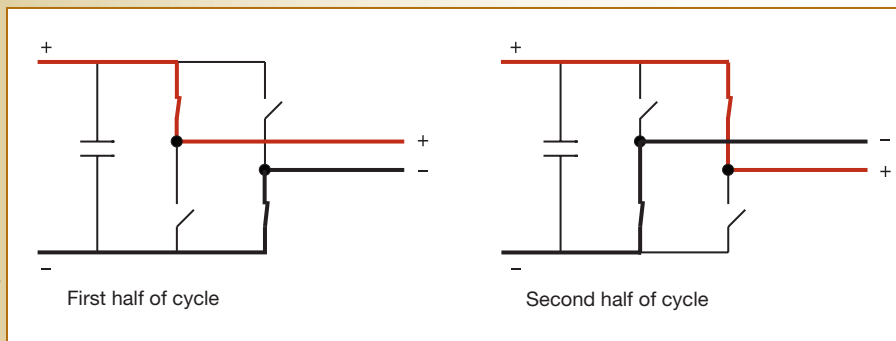

Courtesy: solren.com

**Diagram 1** An H-bridge circuit performs the basic conversion from dc to ac power. This solid state switching process is known as *inversion*.

the distant future if more of our energy is produced, stored and consumed by means of dc power. Today, the technology exists to boost dc electricity to high voltages for long distance transfer, but it is very complex and costly. For the foreseeable future, ac will carry electricity between our power plants, cities, homes and businesses.

In an inverter, dc power from the PV array is inverted to ac power via a set of solid state switches—MOSFETs or IGBTs—that essentially flip the dc power back and forth, creating ac power. Diagram 1 shows basic H-bridge operation in a single-phase inverter.

**Maximum power point tracking.** The method an inverter uses to remain on the ever-moving maximum power point (MPP) of a PV array is called *maximum power point tracking* (MPPT). PV modules have a characteristic I-V curve that includes a short-circuit current value ( $I_{sc}$ ) at 0 Vdc, an open-circuit voltage ( $V_{oc}$ ) value at 0 A and a “knee” at the point the MPP is found—the location on the I-V curve where the voltage multiplied by the current yields the highest value, the maximum power. Diagram 2 (p. 70) shows the MPP for a module at full sun in a variety of temperature conditions. As cell temperature increases, voltage decreases. Module



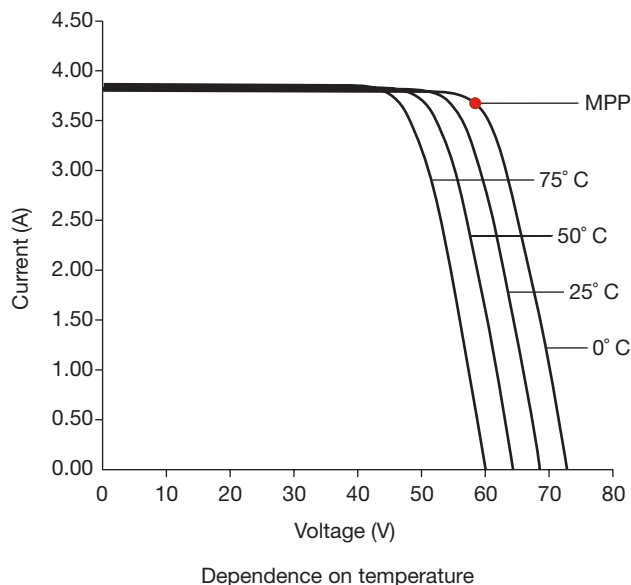

**Diagram 2** The knee, or maximum power point, of the I-V curve varies dramatically according to the effects of both cell temperature, as shown here, and irradiance.

performance is also irradiance dependent. When the sun is brighter, module current is higher; and when there is less light, module current is lower. Since sunlight intensity and cell temperature vary substantially throughout the day and the year, array MPP current and voltage also move significantly, greatly affecting inverter and system design.

The terms *full sun* or *one sun* are ways to describe the irradiance conditions at STC (1000 W/m<sup>2</sup>). Sunlight intensity varies from nothing to full sun or a little more than one sun in some locations and conditions. This means that PV output current can vary from zero to full array rating or more. Inverters need to work with arrays at their lowest voltages, which occur under load on the hottest days, as well as at their highest voltages, which occur at unloaded open circuit array conditions on the coldest days. In some climates, temperatures can vary by 100°F or more, and PV cell temperatures can vary by 150°F. This means array voltage can vary by ratios of nearly 2:1. A string of 22 Evergreen ES-A-210 modules, for example, will reach a Voc of 597 Vdc with a cell temperature of -30°C (-22°F). The MPP voltage (Vmp) can get as low as 315 Vdc in an ambient temperature of 50°C (122°F). In most cases, the maximum power point voltage operates over a 25% variation. However, this number is lower in regions with more consistent year-round temperatures, such as San Diego, California, and is higher in regions where temperature varies more, such as the Midwest and

Northeast. Finding the array’s MPP and remaining on it, even as it moves around, is one of the most important grid-direct solar inverter functions.

**Grid disconnection.** As required by UL 1741 and IEEE 1547, all grid-tied inverters must disconnect from the grid if the ac line voltage or frequency goes above or below limits prescribed in the standard. The inverter must also shut down if it detects an *island*, meaning that the grid is no longer present. In either case, the inverter may not interconnect and export power until the inverter records the proper utility voltage and frequency for a period of 5 minutes. These protections eliminate the chance that a PV system will inject voltage or current into disconnected utility wires or switchgear and cause a hazard to utility personnel. If an inverter remained on or came back on before the utility was reliably reconnected, the PV system could backfeed a utility transformer. This could create utility pole or medium voltage potentials, which could be many thousands of volts. A significant battery of tests is performed on every grid-tied inverter to make certain that this situation can never occur.

Table 1 shows the voltage and frequency limiting values and the time periods that the inverter has to be offline, referred to as *clearing times*. Notice that some values are different for inverters under 30 kW and those over 30 kW. Three-phase commercial inverters over 30 kW have limits that can be adjusted with the permission of the local utility. This can be very useful in an area with a fluctuating grid, which often results in a significant loss of energy. Long utility lines, areas with heavy load cycling or an unstable island of power grids can all contribute to

CONTINUED ON PAGE 72

## Grid Limits for Inverters

Inverter type, size and voltage	Voltage range [V]	Clearing time(s) (seconds)	Frequency range [Hz]	Clearing time(s) (seconds)
Residential 240 Vac	V < 211.2	2.00	f > 60.5	0.16
	211.2 < V < 264	operational	f < 59.3	0.16
	264 < V	1.00	59.3 < f < 60.5	operational
Commercial, 3-phase 208 Vac, <30 kW inverter	V < 104	0.16	f > 60.5	0.16
	104 < V < 183	2.00	f < 59.3	0.16
	183 < V < 228.8	operational	59.3 < f < 60.5	operational
	228.8 < V < 249.6	1.00	—	—
Commercial, 3-phase 480 Vac, >30 kW inverter	249.6 < V	0.16	—	—
	V < 240	0.16 <sup>1</sup>	f > 60.5	0.16
	240 < V < 422.4	2.00 <sup>1</sup>	57.0 < f < 59.8	0.16 <sup>1</sup>
	422.4 < V < 528	operational	f < 57.0	0.16
	528 < V < 576	1.00 <sup>1</sup>	59.8 < f < 60.5	operational
	576 < V	0.16 <sup>1</sup>		

<sup>1</sup> Per IEEE 1547 these values may be adjustable in an inverter over 30 kW with utility permission.

**Table 1** Utility grid voltage and frequency limits for grid-tied PV inverters as required by UL 1741 and IEEE 1547.

Courtesy: solren.com

grid fluctuation. If a PV system significantly underperforms as a result (beyond nuisance tripping), adjusting the inverter limits can be beneficial.

UL 1741 and IEEE 1547 also require that inverters not create a power island. This means that if the utility goes out, the inverter cannot remain on, producing power to any load or portion of a building load, including rotating or oscillating loads. For example, even if the building's load is similar or exactly balanced with the output of the PV system, the inverter may not remain on if the utility is not present. Algorithms for detecting anti-islanding must constantly check to see that the utility grid is really present. A specially tuned "resonant load" set up to mirror the utility tests this inverter function. The resonant load is made up of a very specific inductive, capacitive and resistive network with many settings. Its goal is to attempt to trick the inverter's anti-islanding algorithm into thinking that the utility is really there, at many different prescribed power levels called out in the UL 1741 standard. This load is connected to the inverter operating at full power, and the grid is connected. The resonant load is set to the exact output power of the inverter. When the whole system is stable, the utility is disconnected while the resonant load maintains voltage and frequency within the inverter's limits. The inverter has a maximum of 2 seconds to successfully recognize that the grid is disconnected and shut off.

**Integration and packaging.** Other required equipment built into or included with an inverter includes: ac disconnection means, both manual and automatic; dc disconnection means; EMI and RFI filtering equipment; transformer (if the inverter is transformer-based); cooling system; GFDDI circuit; LED indicators or LCD display; communication connections for PC or Internet data monitoring; and the product packaging.



Courtesy: solren.com (2)

**Inverter packaging** The power electronic module, such as this compact 55-pound power module from a 100 kW PV inverter, is just one of the many components that are integrated into the final inverter package.

Manual ac and dc disconnection means are designed into inverters or PV systems so that the inverter can be disconnected from the grid and the PV array if service technicians, installers or other qualified personnel need to turn off the inverter or access the main inverter enclosure. Automatic ac disconnection means—such as an ac contactor—are used to minimize or totally eliminate nighttime tare losses and reduce susceptibility to damage from nighttime power surges and lightning strikes. Disconnecting power supplies, chips and components of all types at night also extends their service life.

Inverter packaging brings all the components into a single, shippable unit. (The largest 3-phase CONTINUED ON PAGE 74)

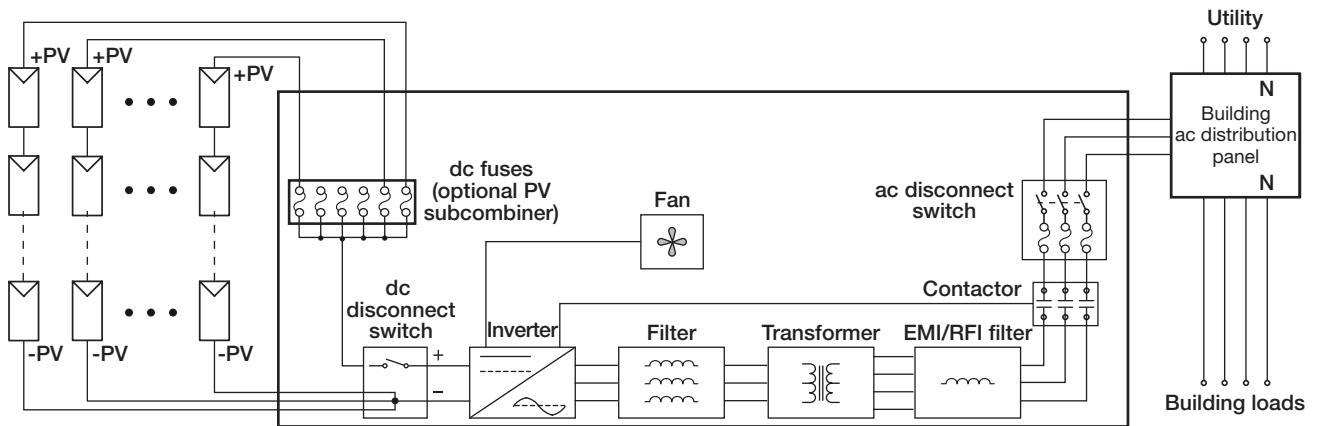

Ground fault detection/interrupt not shown.

**Diagram 3** The major equipment included in an integrated inverter package is detailed in this schematic for a representative 3-phase, central inverter.



Courtesy solren.com (2)

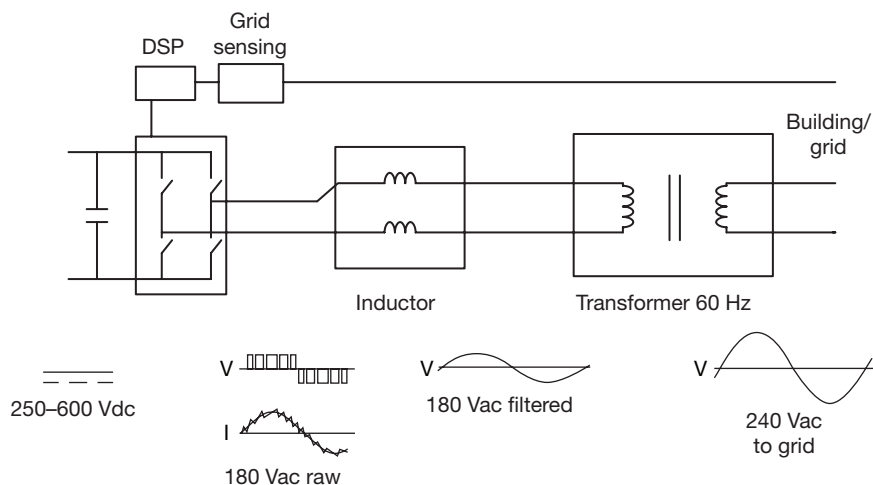

**Diagram 4** A 60 Hz, transformer-based, single-phase inverter circuit.

inverter packages, for commercial and utility scale applications, may ship as more than one enclosure.) Packaging also protects the inverter from the outside elements and keeps unintended guests, human or otherwise, away from the equipment. The use of high quality materials and finishes is necessary to meet the needs of the application. The service life of a PV inverter, for example, requires the use of corrosion-resistant fasteners, like stainless steel screws, to ensure that individual components can be accessed and serviced over 25 years.

## KEY INVERTER COMPONENTS

In this section, we discuss key inverter components. As a starting point, basic inverter operation is illustrated by looking at a single-stage, single-phase, 60 Hz transformer-based inverter. Additional inverter topologies are explained subsequently.

**Solid state switches.** All inverters today use some combination of power semiconductors—IGBTs, MOSFETS or both in some cases—to invert dc to ac power. Other key components in the main power inversion circuit are inductor(s), capacitors and a transformer, either 60 Hz or high frequency. The latter is used in transformer-based inverters to adjust voltage levels as needed by the topology and to provide galvanic isolation between the solar

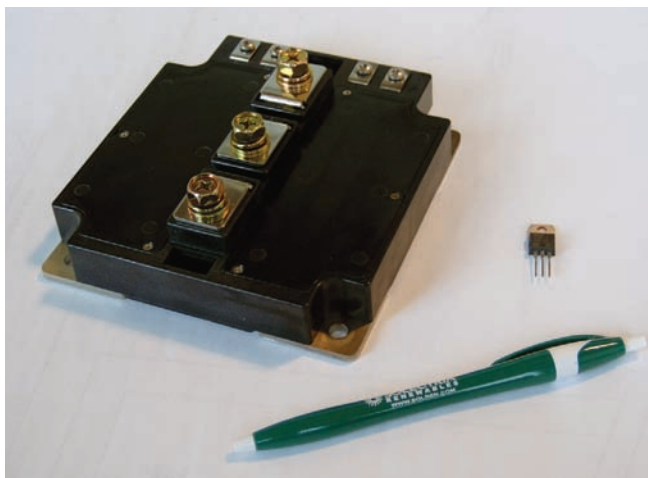

**Solid state switches** These solid state switches—a 1,200 V, 600 A IGBT and a 20 A, 800 V MOSFET—both convert dc to ac power within an inverter.

dc input on one side and the inverter's ac output to the grid on the other. Single stage products like 60 Hz transformer-based string inverters typically use an H-bridge for inversion from dc to ac, as shown in Diagram 1 (p. 69).

Diagram 4 shows all the key components in a single stage inverter, including the H-bridge circuit. The switches at the far left represent the power semiconductor switches. By alternately closing the top left and bottom right switches, then the top right and bottom left switches, the dc voltage is inverted from positive to negative, creating a rectangular ac waveform.

In a grid-interactive, 60 Hz transformer-based inverter, however, the output current needs to be a sine wave form. This requires a more complex operation. The

H-bridge puts out a series of on-off cycles to draw an approximated sine wave shape. This is known as *pulse width modulation* (PWM). With a 250 Vdc to 600 Vdc input, the H-bridge circuit for a typical 60 Hz transformer-based string inverter will put out an approximated sine wave with an ac voltage of about 180 Vac. The role of the components after the H-bridge is to smooth and change the magnitude of that approximated sine wave.

**Magnetics.** The string inverter in Diagram 4 contains several pieces of equipment that are referred to as *magnetics* or *magnetic components*. These include the inductor and the transformer, shown to the right of the H-bridge. These magnetic components filter the waveshapes resulting from the

PWM switching, smoothing out the sine waves, and bring ac voltages to the correct levels for grid interconnection. The magnetics also provide isolation between the dc circuits and the ac grid.

Note that the ac waveform entering the inductor is raw and triangular; but on leaving the device, it is a clean 180 Vac sine wave. Because 180 Vac cannot be directly connected to the utility grid, it goes through a 60 Hz transformer. The resulting smooth, sinusoidal 208, 240 or

CONTINUED ON PAGE 76



**Creating clean sine waves** The inductor transforms raw ac waveforms created by the H-bridge into clean sine waves. (On left, a 20 A inductor typical of a residential string inverter; on right, a 300 A inductor used in large central inverters.)

277 Vac inverter output is connected to the grid. Grid synchronous operation is made possible by grid sensing feedback. Grid voltage information is provided to the inverter's digital signal processor (DSP) or microcontroller, the device that controls the H-bridge.

Magnetics are labor and material intensive, and their costs are tied to expensive commodities like copper and iron. They can also take a costly toll on system performance, and careful design is needed to achieve maximum efficiency. There are two main loss components associated with the use of magnetics. The first component includes core losses,

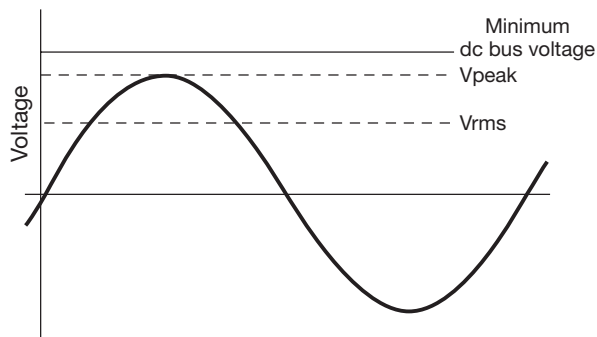

**Diagram 5** The inverter's dc bus voltage must be higher than the peak ac voltage on the primary side of the transformer to create ac power from dc.

which involve the magnetic material (such as iron laminations, magnetic ribbon or sintered powdered material) and gap losses, which result when the magnetic components have a gap between core halves, for example. The second loss component is the conductor or coil loss. These are simply the resistive losses in the many coils of wire around the magnetic cores. Good inverter design needs to minimize both types of losses.

**Minimum dc input voltage.** A wide dc input voltage window is beneficial to PV system designers and installers, since solar arrays operate over a wide voltage range. An even wider voltage window is required to enable designers to select between a wide range of PV products and string configurations. Achieving this wide dc input voltage range is not easy, because inverter designers have to balance concerns like efficiency, circuit complexity and cost.

The laws of physics also limit inverter designers. The inverter's dc input bus voltage needs to be greater than the peak of the ac voltage on the primary side of the transformer. In order to maintain this relationship at all times, an additional control and safety margin is required. With a minimum PV input voltage of 250 Vdc, for example, the highest amplitude ac sine wave you can create is about 180 Vac, as illustrated in Diagram 5

The PV input voltage, of course, will greatly exceed 250 Vdc in many array layouts or temperature and light conditions. If 250 Vdc is selected as the inverter's lower dc voltage design limit, then the H-bridge will always create an ac sine wave with a magnitude of 180 Vac. This is true even when the dc voltage present is 300 Vdc, 400 Vdc or higher. This is because the rest of the 60 Hz transformer-based inverter needs to operate on a relatively fixed ac voltage. The voltage on the utility side of the inverter's transformer—the secondary side—is fixed within a small range of variation. Inverter designers must set the voltage on the primary side of that transformer accordingly.

**Capacitors.** The most important use of capacitors in the inverter power stage is for filtering ripple currents on dc lines. Ripple is an undesirable phenomenon caused by power semiconductor switching. Capacitors are also used to keep the dc bus voltage stable and minimize resistive losses over the dc wiring between the PV array and the inverter, since the resulting current from the array to the inverter dc bus is constant. A relatively smooth dc voltage and current at the input of the inverter allow good PV voltage regulation, which results in an MPP tracking algorithm that works well and has high accuracy.

Lower frequency capacitors, typically electrolytic types, make up the main capacitance on typical inverter bus structures. These have very high capacitance and the ability to filter large ripple currents. High frequency capacitors, typically film capacitors of various types, CONTINUED ON PAGE 78

are also used for filtering out high frequency noise and spikes from power semiconductor turn-on and turn-off cycles.

Capacitors, particularly electrolytic types, are susceptible to failure from long-term operation in hot environments. Inverter designers have to carefully select the proper capacitors to ensure that they can take the heat and absorb the high ripple currents that are possible. Selecting high-grade versions and using more than are required to minimize heating of the capacitors caused by the ripple current are typical approaches.

A different and newer approach, seen in some commercial 3-phase inverters, involves the use of high capacity film capacitors. Unlike electrolytic capacitors, film capacitors cannot dry out and will therefore last longer. They are also less affected by temperature. The trade-off is that film capacitors are more costly and take up more space. However, that trade-off can be very worthwhile, especially on large inverters where space is less an issue. Commercial and industrial PV systems will produce large quantities of electricity over 25 years or more, so the inverter needs to be as reliable and long-lasting as possible.

**Maximizing efficiency.** Optimizing efficiency, or reducing loss, is an important part of inverter design and component selection. The goal is to optimize the inverter for maximum efficiency, while maintaining high reliability and delivering a product at a good price. Because there are losses associated with each, components of efficient design include the choice



**Removing ripple** The capacitor on the left is an electrolytic type, and the others are various film capacitor types. Capacitors filter ripple currents and stabilize the dc bus.



**Thermal management** Many inverters, like the 100 kW central inverter shown here, provide different temperature zones for major components. A relatively cool section protects sensitive power electronics on the top, while a higher temperature section houses the magnetics below.

of IGBT or MOSFET power semiconductor switches, switching frequency, method of switch control and turn-on and turn-off method. Many of these choices require a careful balance of waveform smoothness, noise, reliability and efficiency.

Because the installed cost for PV systems is high, requiring subsidies to make financial sense, the benefits of high efficiency are compelling. A 1% increase in inverter efficiency translates into immediate and long-term savings, a result of increased energy harvest and increased compensation for that energy. An even more powerful way to look at efficiency on a 100 kW PV system is that a 1% gain in efficiency means you could install 1 kW less of PV. This results in upfront savings of \$6,000 to \$8,000.

As the installed cost for PV decreases, inverter efficiency may become less critical than it is today. However, it will always be better to convert as much PV power into ac power as possible. To do otherwise results in waste heat. With greater inverter efficiency, less energy and fewer materials are needed for the inverter's cooling system, resulting in prolonged inverter life.

**Thermal performance.** As far as thermal performance is concerned, the first goal of inverter design is to minimize loss. The next goal is to minimize temperature gain for maximum inverter component life. The last step is to minimize power requirements and energy consumed for cooling system needs.

Where a significant temperature differential exists between inverter components, different types of components are often separated into temperature zones within the inverter's overall enclosure. This is especially useful when lower temperature components are also more sensitive to higher temperatures. This approach is utilized in many 60 Hz



### Temperature zones

These thermal images were taken inside the inverter on the facing page after 6 hours of full-power operation at an ambient temperature of 70°F. The maximum temperature recorded in the electronics section of the inverter is 120°F, even though the highest temperature recorded in the magnetics section is 183°F.

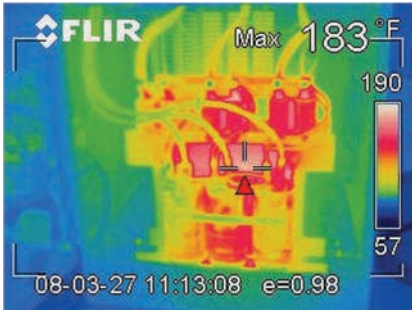

Courtesy solren.com

transformer-based inverter designs, both string and central types. The 60 Hz transformers can operate at much higher temperatures than semiconductors, capacitors and other electronic components.

**Software and monitoring.** To reliably control the inverter, the software designed to run on the inverter's digital signal processor or microcontroller is developed over years of code writing and debugging. The most critical control is the one driving the power stage. This creates the PWM waveforms that generate the sine waves ending up on the utility grid and at the building's loads. Software also controls the inverter's interaction with the grid and drives all the appropriate UL 1741 and IEEE 1547 required controls and events. Another part of the software controls the MPPT function that varies the dc voltage and current level as required to accurately and quickly follow the moving MPP of the PV array. All of these major functions, as well as a multitude of others, are carried out in unison like an orchestra. Software is used to drive the contactor that places the inverter on the grid in the morning and off the grid at night. Software controls temperature limits and optimizes cooling system controls. Software, its development history and robustness, is a critical element in any inverter.

A completely different aspect of the inverter's software is related to communication with other inverters, PCs and data onto the Internet, as well as building management systems. Sometimes this is done by separate devices, such as data monitoring devices or Internet gateways that gather data from the inverter or integrated software and hardware within the inverter. Data monitoring is an important part of a PV system since it lets owners and installers know its



Courtesy solren.com (2)



**DSP control board** Critical inverter functions rely on the software run on the DSP.

status and provides quick alerts if there are inverter or PV system faults. Since an inverter already measures and calculates much information regarding ac and dc sides of the PV system, it is typically a convenient place to gather this data, process it and place it on the Internet, for example.

Some inverter manufacturers provide PC or Web based monitoring options; some inverters are compatible with third-party monitoring systems; and some inverters have both options available. Monitoring is one area of inverter

development that is evolving quickly. Several inverter manufacturers or third-party monitoring providers offer advanced features, like revenue grade monitoring, PV string and subarray monitoring, weather monitoring and inverter-direct monitoring.

**ALTERNATIVE INVERTER TOPOLOGIES**

So far we have discussed the design and operation of a single-stage, single-phase, 60 Hz transformer-based string inverter. Other common inverter design topologies and applications include 3-phase inverters, high frequency inverters, bipolar inverters, transformerless inverters and battery based inverters. In some cases a single inverter product may incorporate several of these features. This is the case with Solaron inverters from Advanced Energy, which are 3-phase, bipolar and transformerless products. While we do not address this exact combination of features in this section, we do explore the most common alternative inverter topologies for PV applications.

**3-phase, 60 Hz transformer-based inverters.** The operation of a 60 Hz transformer-based, 3-phase inverter is very similar to that of the string inverter. The difference is that a central inverter has three phase outputs instead of two. In order to generate three phase outputs, 60 Hz transformer-based central inverters typically use a 3-phase bridge. This is a bridge with a 6-switch design.

Diagram 6 shows a 3-phase, 6-switch bridge. The RMS voltage of the PWM-created sine CONTINUED ON PAGE 82

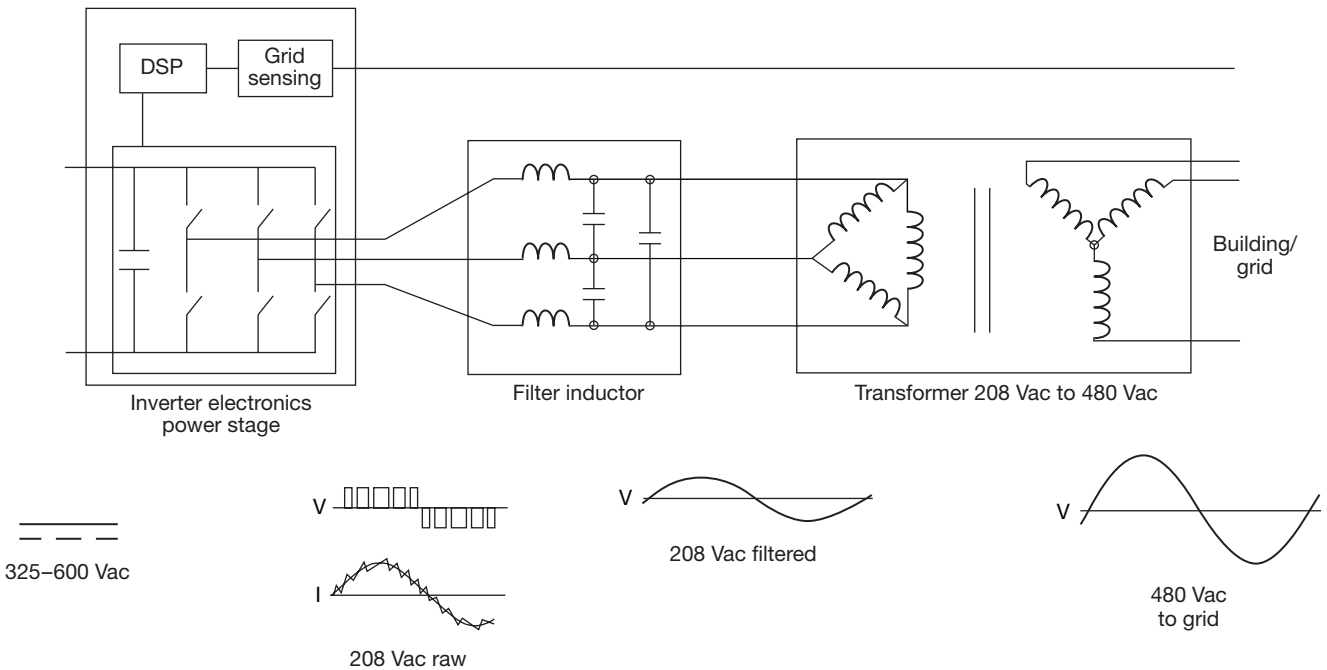

**Diagram 6** A 60 Hz transformer-based, 3-phase inverter circuit.

## Distribution of PV Inverter Topologies in North America

Courtesy solren.com (2)

Single-Phase Grid-Direct Inverters			Off-Grid Inverters	3-Phase Central Inverters	
60 Hz Xfmr	HF Xfmr	Xfmr-less	60 Hz Xfmr	60 Hz Xfmr	Xfmr-less
PV Powered	Fronius	Power-One	Apollo	PV Powered	Advanced Energy
SMA	Kaco		Magnum	Satcon	
	Solectria		OutBack Power	SMA	
	Xantrex		SMA	Solectria	
			Xantrex	Xantrex	

**Table 2** The distribution of 60 Hz transformer versus high frequency transformer versus transformerless inverter topologies in string inverters and central inverters.

wave is typically 200 Vac or 208 Vac. This voltage is derived from a minimum PV voltage of 300 Vdc or 330 Vdc, depending on the inverter model and options. As with the previous single-phase example (Diagram 4, p. 74), the 3-phase, 60 Hz transformer-based inverter includes an inductor to filter out the PWM-created sine wave and a transformer to convert the filtered waveform to the correct ac voltage. The transformer also isolates the PV system from the grid.

**High frequency string inverters.** Many of the grid-direct string inverters available in North America today utilize high frequency transformers. (See Table 2 for the actual distribution.) High frequency transformer-based inverter circuit topology and operation is quite different from that of 60 Hz transformer-based inverters. High frequency transformers

weigh less, are smaller and cost less than 60 Hz transformers. A high frequency transformer, for example, weighs 10% to 20% of a 60 Hz transformer of the same power level. This allows for a smaller, lighter and easier to install package.

Another advantage of a high frequency transformer-based inverter topology is that it allows for a wide dc input voltage range. This is because of the two-stage design of the inverter. These stages are shown in Diagram 7.

The first block, greatly simplified, represents a voltage boost circuit. This is, therefore, referred to as the *boost stage*. By turning the MOSFET or IGBT on and off, represented here by the switch symbol, under the correct PWM control, the inductor and diode boost the voltage from the input (left) to the output (right) of the circuit.

When the switch is closed, current flows through the inductor in the direction of the minus sign in Diagram 7. When the switch opens, stopping the flow of current through the switch, the voltage is boosted higher. When this happens the diode starts conducting, and the inductor current flows out to the capacitor to the right. This boost circuit accepts an input of 200 Vdc to 600 Vdc and will output a constant 700 Vdc. Again using PWM, the H-bridge converts the high voltage dc from the boost stage to a high frequency ac signal. This is fed through the high frequency transformer, which provides isolation and brings the voltage to the right level for grid interconnection.

The final stage is shown on the right of Diagram 7. An inductor filters out the high frequency switching cycles to

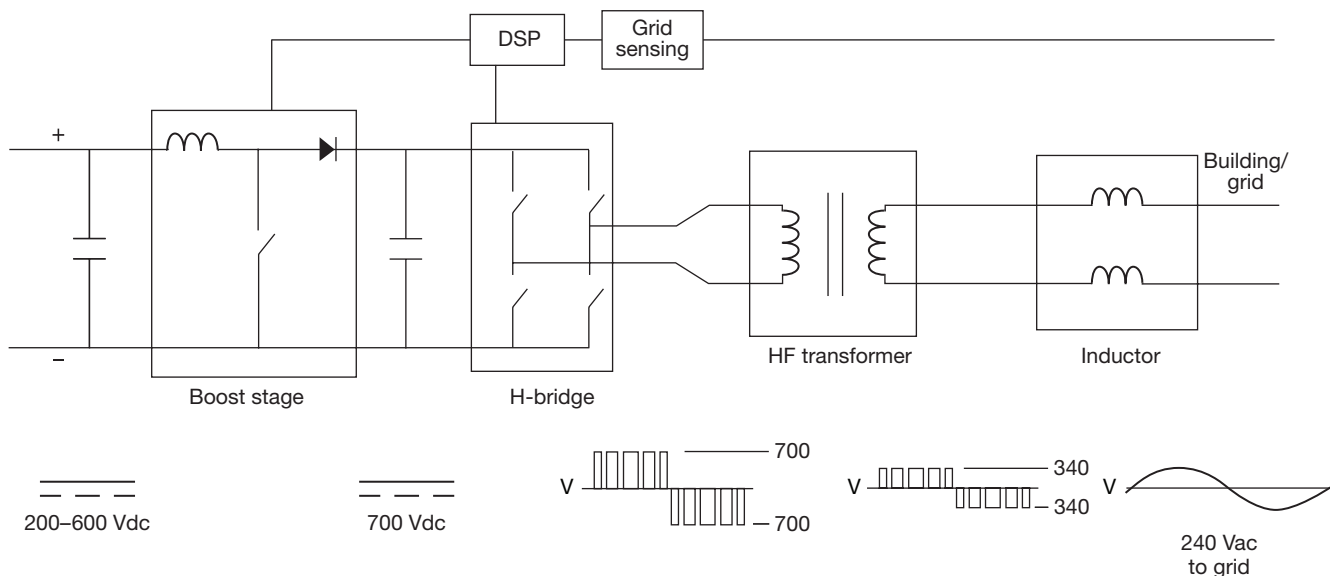

**Diagram 7** A high frequency, transformer-based, single-phase inverter circuit.

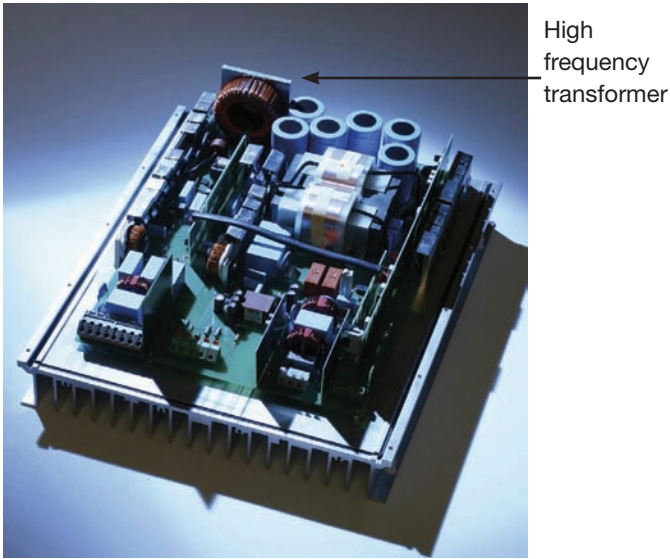

**High frequency transformer** All the semiconductors and magnetics components in this 2.5 kW string inverter are mounted on a common heat sink.

create a smooth, grid quality 208, 240 or 277 Vac 60 Hz sine wave. Grid sensing feedback lets the DSP and its software regulate the H-bridge to constantly create smooth 60 Hz output current at the right voltage. As opposed to single stage inverters, inverters with a voltage booster at the input work most efficiently at high dc input voltage levels.

The disadvantage with a high frequency inverter topology is that more silicon semiconductors are required, resulting in higher costs. However, since copper and iron commodity prices are volatile and trending upward, buying more silicon and less copper and iron is a trade-off that many companies are willing to make. The amount of silicon used for semiconductors in an inverter is quite small, even compared to the smaller magnetic components common in high frequency string inverters. Besides weight and cost reductions, lower losses and less waste heat are additional benefits of smaller high frequency magnetics. These allow for direct mounting to heat sinks, even mixing components of different temperature classes.

**Bipolar inverters.** UL 1741 and the *NEC* restrict the design and operation of grid-tied PV equipment to a maximum potential to ground of no greater than 600 Vdc under any conditions expected for a given site. This is why the maximum dc voltage on most inverters is 600 Vdc. Because of the large temperature swing that PV modules must operate within—especially in regions with high maximum and extreme low minimum ambient temperatures—the voltage range of PV array operation is quite broad. In some cases, the ratio of high to low voltage approaches 2:1. This means that

the nominal operating voltage of a PV array that is designed to have a maximum Voc of 600 Vdc is typically 400 Vdc or less. On warm days, the array voltage might be 350 Vdc to 330 Vdc or even less.

Bipolar topologies allow the inverter designer to make use of dc voltage both above and below ground. Circuit construction is not necessarily different with a bipolar approach; the array is just grounded at a center point rather than at one end or the other. It is possible to use any of the methods described previously for the power stage and operation of a bipolar inverter. There are significant differences, however, in various component ratings since the potential across open dc switches and all dc equipment is now about double at 1,000 Vdc. Also the dc ground fault circuit interrupter needs to detect faults separately on both the positive and the negative side of the array. Especially in commercial and utility scale PV systems, where massive amounts of copper or aluminum conductors are used, higher dc array voltages mean less conductor material, lower costs and, in some cases, improved system efficiency. Special requirements in the *NEC* for bipolar source and output circuits are found in Article 690.7(E).

**Transformerless inverters.** Transformerless operation is popular in Europe, especially for string inverters and increasingly for 3-phase central inverters. The basic premise is that since a building or utility transformer is down the line anyway, another transformer right in or alongside the PV inverter is not needed. Eliminating the transformer reduces cost, size and weight. Doing away with the transformer inside the inverter also eliminates the loss components associated with the transformer, increasing inverter efficiency.

While UL 1741 and the *NEC* allow for the use of transformerless inverters in PV systems, additional requirements apply. These are spelled out in *NEC* 690.35 and include the use of PV Wire, a different version of the double-insulated, single conductor source circuit cable typically used in PV installations. This cable is more expensive than USE-2 or RHW-2 and is less available in the US than in Europe. Over-current protection and dc disconnect requirements are also different, since both positive and negative current-carrying conductors to the inverter are ungrounded.

**Off-grid inverters.** All off-grid inverters are based on 60 Hz transformers. This is probably due to the development of the off-grid industry. Some of the first widely available, affordable inverters in the late '70s and '80s were originally designed for motor homes and recreational use. Products like the Tripp Lite inverters operated on a very basic principle—a 12 Vdc input to a square-wave transistor that fed a transformer. This transformer boosted the voltage more than 10 times to an output of 120 Vac. The output waveform was slightly less than square and was considered a modified sine wave. These crude devices made a considerable buzz,



had low efficiencies and could not be used with certain appliances sensitive to nonstandard sine wave power.

The original inverters popular for use with off-grid solar were the Trace, Heart Interface and one or two other brands. These were originally available with a 12 Vdc input, but 24 Vdc models followed soon thereafter for larger systems. Eventually 48 Vdc versions for even larger and more efficient systems became available, allowing smaller wiring and fewer paralleled batteries. For a given power level, 48 Vdc systems use 50% of the current of a 24 Vdc system and 25% of a 12 Vdc system. The advantages to a higher dc input are quite obvious.

The off-grid inverter models in Table 2 (p. 82) are based on a solid state switching input to a 60 Hz transformer. The transformer boosts the output significantly, for example 12 Vdc or 24 Vdc inverter input to 120 Vac output or 48 Vdc input to 240 Vac output. Note that with a 12 Vdc bus coming into an inverter, the peak of the ac sine wave out of the H-bridge is 12 Vac. This means that the RMS amplitude of the sinusoidal waveform is a mere 8 Vac. The transformer needs to boost this to 120 Vac, a very large ratio of 1:15. Although most modern inverters for off-grid solar applications have a 120 Vac output, several models are available with 240 Vac output. Other models let you stack two or more 120 Vac units for a 240 Vac split-phase electrical service (or simply to service larger loads), and 3-phase configurations are also possible.

Boosting voltage by a large ratio lends itself well to a 60 Hz transformer. Another great advantage of the 60 Hz transformer in this design is that it completely isolates the battery and the ac system from one another, which is a good reliability and safety feature. Working with low voltages means high current levels, MOSFETs with high current ratings and big wires. Considering the task at hand, the manufacturers of these 12 Vdc to 48 Vdc input off-grid inverters have done a great job, achieving admirable efficiencies while maintaining reasonable costs. Most models provide efficiencies in the low 90% range, with the best models approaching 95% peak efficiencies.

### INVERTERS IN THE FUTURE

The PV industry is an exciting place to be. As we charge toward grid parity, market growth in the US and the rest of the world accelerates, outstripping PV module production capacity at times. Inverters remain critical PV system



Future advances in grid-tied inverters will likely include some type of utility interaction to support the grid in times of distress.

components, even though their portion of the overall budget is quite small. In most cases, inverter costs represent on the order of 10% of total system costs; in larger systems, they are well under 10%. Nevertheless, as the PV market matures, cost reduction is a definite trend to watch, even with inverters. Increased competition, higher volumes, new technologies and advanced manufacturing processes will all enter the equation.

A struggle to achieve higher efficiencies exists at all inverter power levels. The top transformer-based residential and commercial inverters achieve CEC efficiencies of 95% to 96% and peak efficiencies above 97%. The industry is quickly reaching a place of diminishing returns, as there are precious few losses to shave off at this point. PV inverter manufacturers continue to work toward increasing efficiency, looking to gain another 0.5% to 1%. Transformerless inverters may already provide that efficiency gain, however. Europe is now driving this technology, and the US will most likely follow once the *NEC* gets more friendly towards ungrounded PV systems.

Higher levels of inverter integration will also come to play in advanced inverter designs. As PV system installation labor increasingly becomes a larger piece of the total installed cost, more components and functionality are added to inverters. Disconnects, subcombiners, string combiners, communications and data monitoring are just a few of the things integrated today by various inverter manufacturers. Adding other functions, such as integrated revenue grade monitoring, PV system weather sensor inputs, interaction with PV array trackers, solar concentrators and other gear, further simplifies overall PV system installation. Increased integration will also result in more building block approaches, simplifying large commercial and utility scale systems and providing a great value in large, very expensive PV systems. Advanced integral data monitoring, providing system performance predictions and reporting, will further optimize system performance. These reports will alert customers or service personnel to potential system issues and gradual changes in array performance before any significant energy production is lost.

Future advances in central grid-tied inverters—and eventually string inverters as well—will likely also include some type of utility interaction to support the grid in times of distress. This might include the inverter remaining online

during a brownout or other voltage events, even during frequency events, giving the utility more time to make adjustments or isolate circuits to remedy the problem and preventing even larger grid instability or a propagated blackout. Currently, if the grid voltage or frequency goes outside of the windows specified in IEEE 1547, all grid-tied inverters must go offline, which likely accelerates grid failure. Utility control of PV inverters and other discontinuous sources might make it possible to remedy some grid problems. Because inverters draw their sine wave current waveforms in many increments, the differential control of these increments can help specifically to adjust the grid voltage waveform, minimizing or correcting power factor or other problems created by certain loads in the area.

Another area for the advancement of inverters and grid-tied renewable energy systems will likely involve energy storage. As a larger portion of our power generation capacity comes from discontinuous sources of energy, like PV and wind, storage becomes more important. A future component of large commercial PV systems might include on-site energy storage with utility control or based on time of use costs for electricity. With increasing amounts of PV power processed by DSP-controlled inverters, there are many critical functions that inverters can incorporate as the industry progresses. As these potentials are realized, PV power will become an increasingly widespread and important portion of our energy infrastructure. ⊕

## » CONTACT

James Worden / Solectria Renewables / Lawrence, MA /  
james@solren.com / solren.com

Michael Zuercher-Martinson / Solectria Renewables / Lawrence, MA /  
michael@solren.com / solren.com

### Resources

Advanced Energy / 800.446.9167 / advanced-energy.com  
Apollo Solar / 203.790.6400 / apollosolar.com  
Evergreen Solar Energy / 508.357.2221 / evergreensolar.com  
Fronius / 810.220.4414 / Fronius-usa.com  
Heliotronics / 781.749.9593 / heliotronics.com  
Kaco Solar / 415.931.2046 / kacosolar.com  
Magnum Energy / 425.353.8833 / magnumenergy.com  
Power One / 866.513.2839 / power-one.com  
PV Powered / 541.312.3832 / pvpowered.com  
Satcon / 617.897.2400 / satcon.com  
SMA Solar Technology / 916.625.0870 / sma-america.com  
Solectria Renewables / 978.683.9700 / solren.com  
Tripp Lite / 773.869.1111 / triplite.com  
Xantrex Technology / 604.422.8595 / xantrex.com